

American Modular Tooling kits provide adaptability for any fixturing need. Kits range in size and complexity from a few to hundreds of components.

Kit Number AMT-10005-xx, CMM Hold-Down Kit, 19 pieces

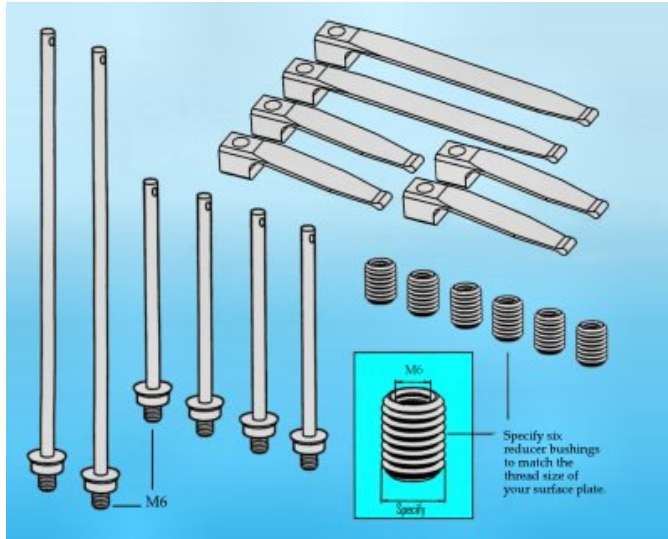

This versatile CMM Hold-Down Kit is ideal for clamping parts to a surface plate or CMM.

1. Reducer bushings are inserted into threaded holes in the plate of the CMM.
2. The vertical clamp posts are screwed into the bushing or the plate.
3. The finger clamps are then fitted over the posts and pressed down to hold the part by tension.

Two clamp lengths and two different post heights are included for maximum versatility.

Kit Components

Part Number	Qty	Description
AMT-16004	4	Finger Clamp l=60mm
AMT-16005	2	Finger Clamp l=105mm
AMT-16012	4	Clamp Post, M6, h=60mm
AMT-16014	2	Clamp Post, M6, h=130mm
AMT-16021	1	Grid Base Plate, M6, 200x200x25mm
See Chart	6	Reducer Bushing

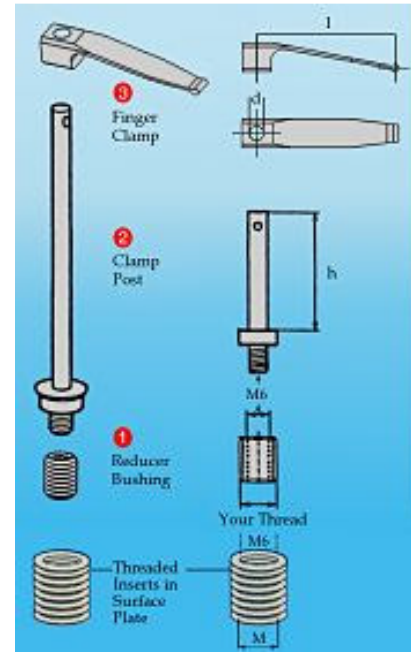

Shown with 200mm plate. Other sizes are available. AMT grid base plates are threaded with recessed bores. Reducer bushings match "M" dimension to the threads in your surface plate.



Kit Order Numbers

- AMT-10005-3/8 Kit with 3/8" bushings
- AMT-10005-M8 Kit with M8 Bushings
- AMT-10005-M10 Kit with M10 Bushings
- AMT-10005-M12 Kit with M12 Bushings

